

Anúncio Convite

Aquisição ao abrigo do Decreto-lei n.º 60/2018, de 3 de agosto

(Português)

Referência (indicar na proposta):	2023-96
Entidade Adjudicante:	UNINOVA – Instituto de Desenvolvimento de Novas Tecnologias PT501797173
Projecto:	UIDB/00066/2020
Data da Publicação:	11/10/2023
Prazo final da proposta:	3 dias uteis após a data da publicação
Objeto do contrato:	Fornecimento, maquinação e montagem das peças metálicas, de acordo com os desenhos fornecidos em anexo, para criação de um sistema Ciber Físico constituído por circuitos e mecanismos para suportar demonstradores sobre CPS a ser instalados na célula do UNINOVA.
Características Técnicas:	Descritas nos Desenhos Fornecidos em formato .PDF
Critério de Adjudicação:	Critério da proposta economicamente mais vantajosa na modalidade monofactor: Preço mais baixo
Critério de desempate:	Nos termos da alínea c), do n.º 5 do artigo 74.º do CCP, em caso de empate, o sorteio, a desenrolar presencialmente com o júri do concurso e com os interessados, em data, hora e local a comunicar com a antecedência mínima de três dias, do qual será lavrada ata por todos os presentes
Preço base (sem IVA):	5200,00€ (Cinco mil e duzentos Euros)
Condições de pagamento:	60 dias após a data de emissão da fatura.
Condições de faturação:	Submissão na plataforma de faturação eletrónica Ilink (apenas para grandes empresas)
Enviar proposta para:	compras@uninova.pt e jab@uninova.pt
Responsável pela avaliação de propostas:	José António Barata de Oliveira
Gestor do Contrato:	José António Barata de Oliveira
Audiência prévia:	3 dias úteis após data notificação da proposta de adjudicação
ANEXOS	Anexo I – Desenhos em formato PDF

Invitation Announcement

Acquisition under Decree-Law n.º 60/2018, of 3 de August

(English)

Reference (indicate in the proposal):	2023-96
Contracting Authority:	UNINOVA – Instituto de Desenvolvimento de Novas Tecnologias PT501797173
Project:	UIDB/00066/2020
Publication Date:	11/10/2023
Proposal Deadline:	3 business days after the publication date
Subject of the contract:	Supply, machining and assembly of metal parts, in accordance with the attached drawings, to create a cyber-physical system consisting of circuits and mechanisms to support CPS demonstrators to be installed in the UNINOVA cell.
Technical Characteristics:	PDF and DXF format drawing Attached
Selection criteria:	Criteria of the most economically advantageous proposal in the single-factor modality: lowest price.
Tiebreaker criteria:	Under the terms of subparagraph c), of paragraph 5 of article 74 of the CCP, in the event of a tie, the draw, to be carried out in person with the competition jury and with the interested parties, on a date, time and place to be communicated with at least three days in advance, of which minutes will be drawn up by all those present.
Base Price (VAT not included):	5200€ (Five thousand and two hundred euros)
Payment Conditions:	60 days after invoice.
Invoicing Conditions:	Submission on the iLINK electronic invoicing platform (Large Business company only)
Send proposals to:	compras@uninova.pt and jab@uninova.pt
Person in charge of proposals analysis:	José António Barata de Oliveira
Contract manager:	José António Barata de Oliveira
Prior hearing:	3 business days from the date of notification of award proposal
Annex:	Annex I - PDF format drawing

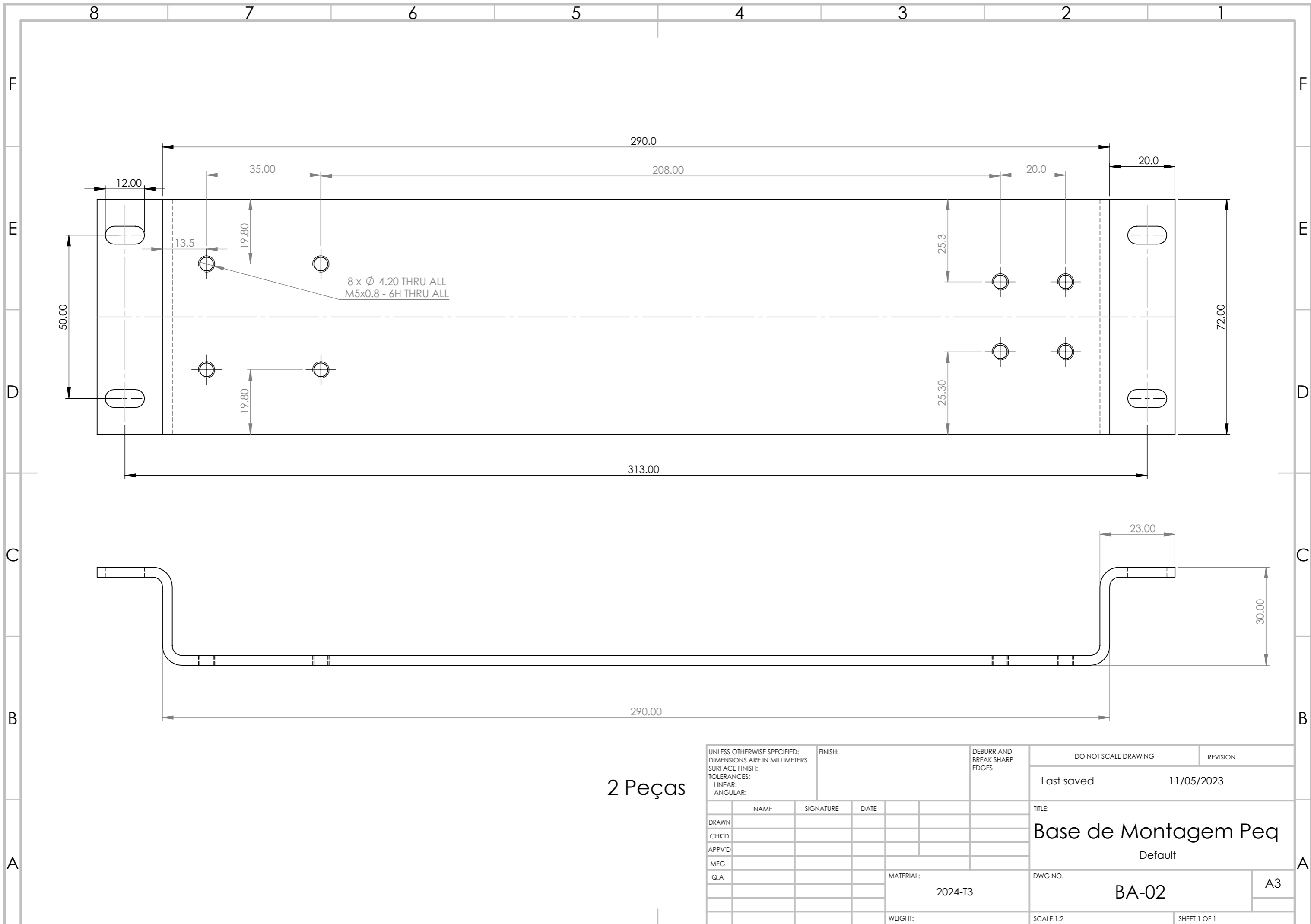

8 x Ø 4.20 THRU ALL
M5x0.8 - 6H THRU ALL

2 Peças

UNLESS OTHERWISE SPECIFIED: DIMENSIONS ARE IN MILLIMETERS SURFACE FINISH: TOLERANCES: LINEAR: ANGULAR:			FINISH:		DEBURR AND BREAK SHARP EDGES		DO NOT SCALE DRAWING		REVISION	
							Last saved		11/05/2023	
							TITLE:		Base de Montagem Peq	
							Default			
DRAWN			NAME		SIGNATURE		DATE		DWG NO.	
CHK'D									BA-02	
APPV'D									A3	
MFG									SCALE:1:2	
Q.A							MATERIAL:		SHEET 1 OF 1	
							2024-T3			
							WEIGHT:			

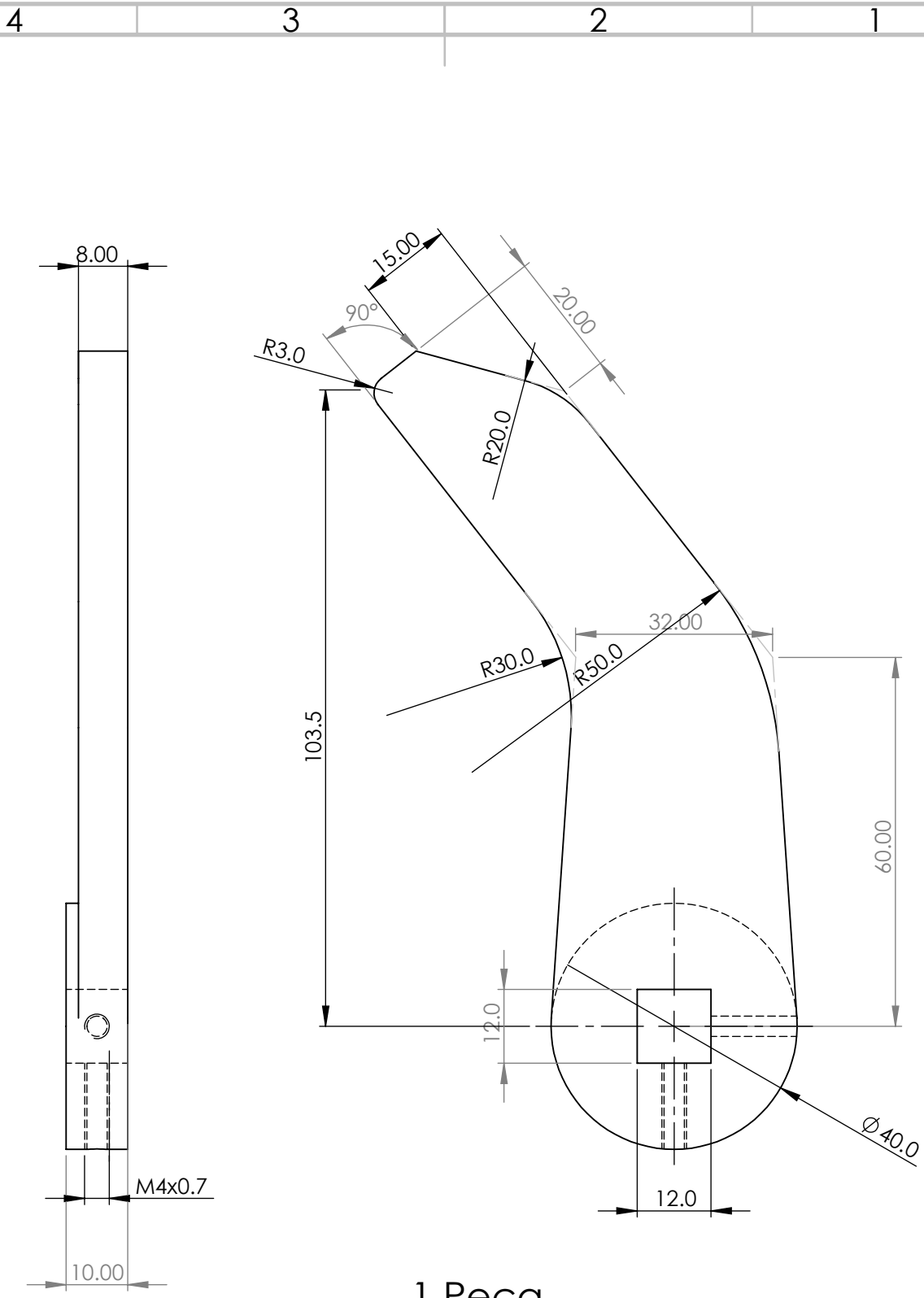

1 Peça

UNLESS OTHERWISE SPECIFIED:
 DIMENSIONS ARE IN MILLIMETERS
 SURFACE FINISH:
 TOLERANCES:
 LINEAR:
 ANGULAR:

FINISH:

DEBURR AND
 BREAK SHARP
 EDGES

DO NOT SCALE DRAWING

REVISION

Last saved

09/05/2023

	NAME	SIGNATURE	DATE
DRAWN	Pamies Teixeira		
CHK'D			
APPV'D			
MFG			
Q.A			

TITLE:	
Biela Mandada Peq Direita	
DWG NO.	BM-02
	A4
WEIGHT:	SCALE:1:1
	SHEET 1 OF 1

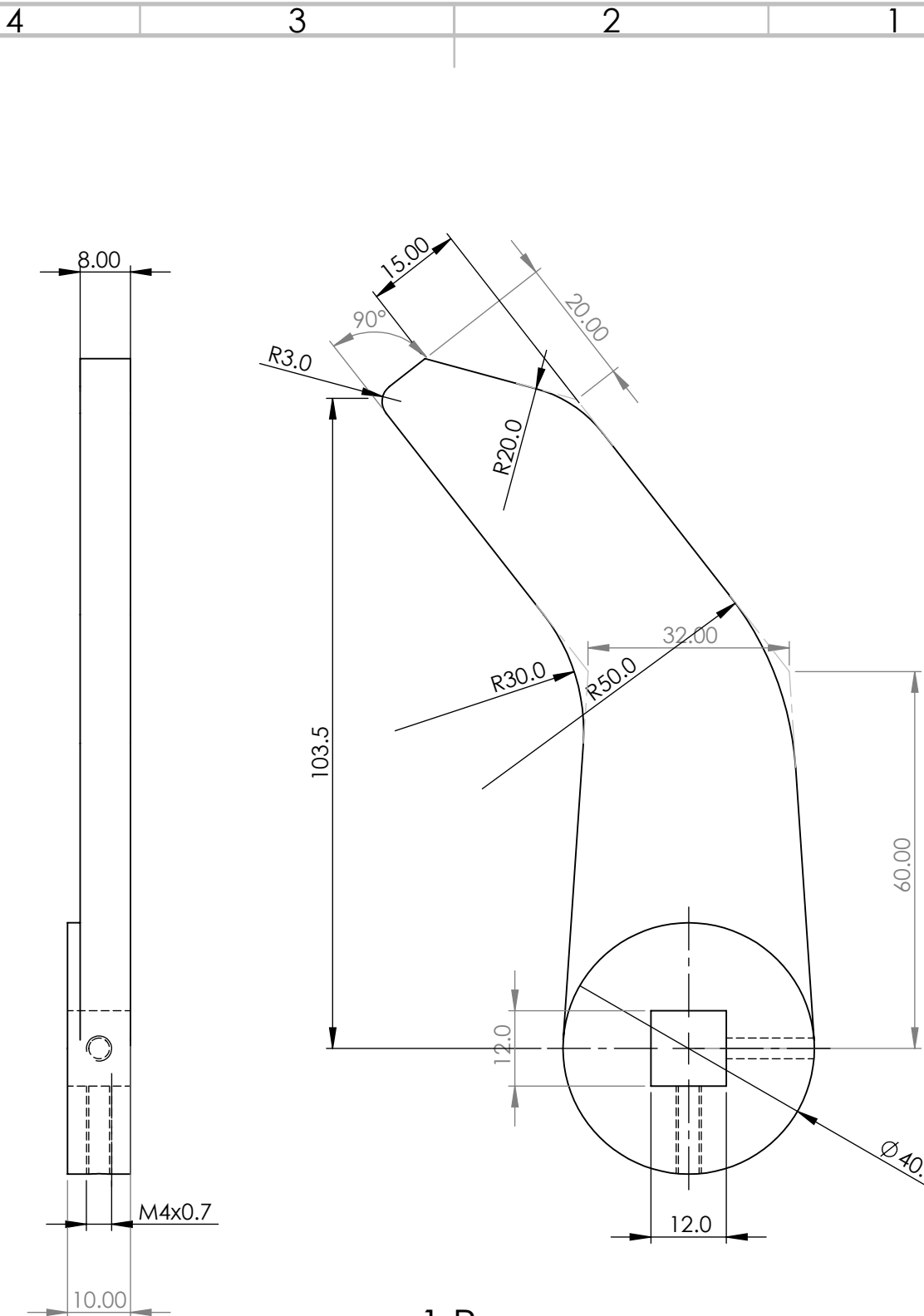

1 Peça

UNLESS OTHERWISE SPECIFIED:
 DIMENSIONS ARE IN MILLIMETERS
 SURFACE FINISH:
 TOLERANCES:
 LINEAR:
 ANGULAR:

FINISH:

DEBURR AND
 BREAK SHARP
 EDGES

DO NOT SCALE DRAWING

REVISION

Last saved

09/05/2023

	NAME	SIGNATURE	DATE
DRAWN	Pamies Teixeira		
CHK'D			
APPV'D			
MFG			
Q.A			

TITLE:
 Biela Mandada Peq
 Esquerda

MATERIAL:

Material <not specified>

DWG NO.

BM-02

A4

WEIGHT:

SCALE:1:1

SHEET 1 OF 1

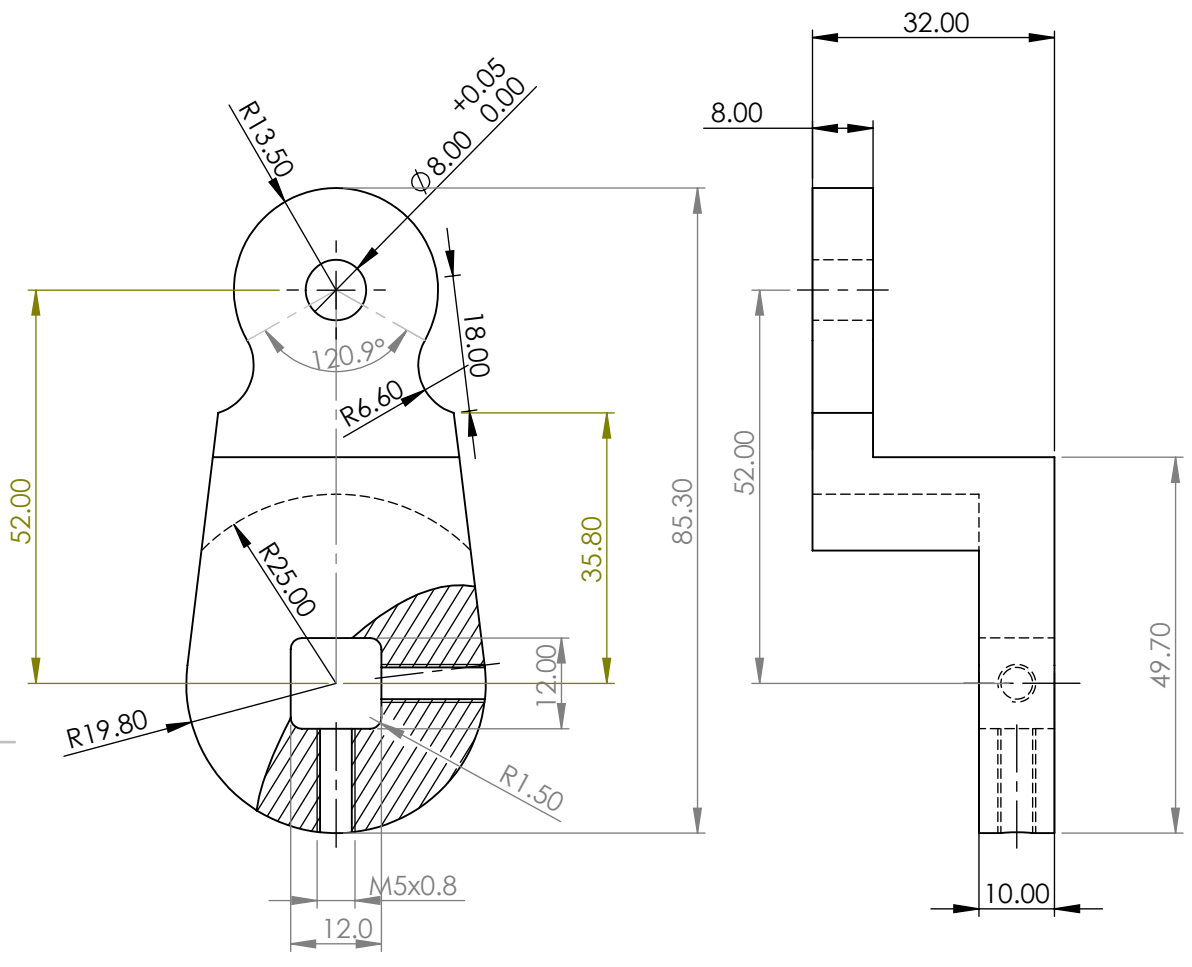

8 Peças p/ Mesa Grande
4 Peças p/ Mesa Pequena

UNLESS OTHERWISE SPECIFIED:
DIMENSIONS ARE IN MILLIMETERS
SURFACE FINISH:
TOLERANCES:
LINEAR:
ANGULAR:

FINISH:

DEBURR AND
BREAK SHARP
EDGES

DO NOT SCALE DRAWING

REVISION

Last saved

11/05/2023

	NAME	SIGNATURE	DATE
DRAWN	Pamies Teixeira		
CHK'D			
APPV'D			
MFG			
Q.A			

TITLE:		Biela Mandante	
MATERIAL:		2024-T3	
DWG NO.:		BD-01	
WEIGHT:		SCALE:1:1	
		SHEET 1 OF 1	

Conjunto Mesa Pequena (Longitudinal)

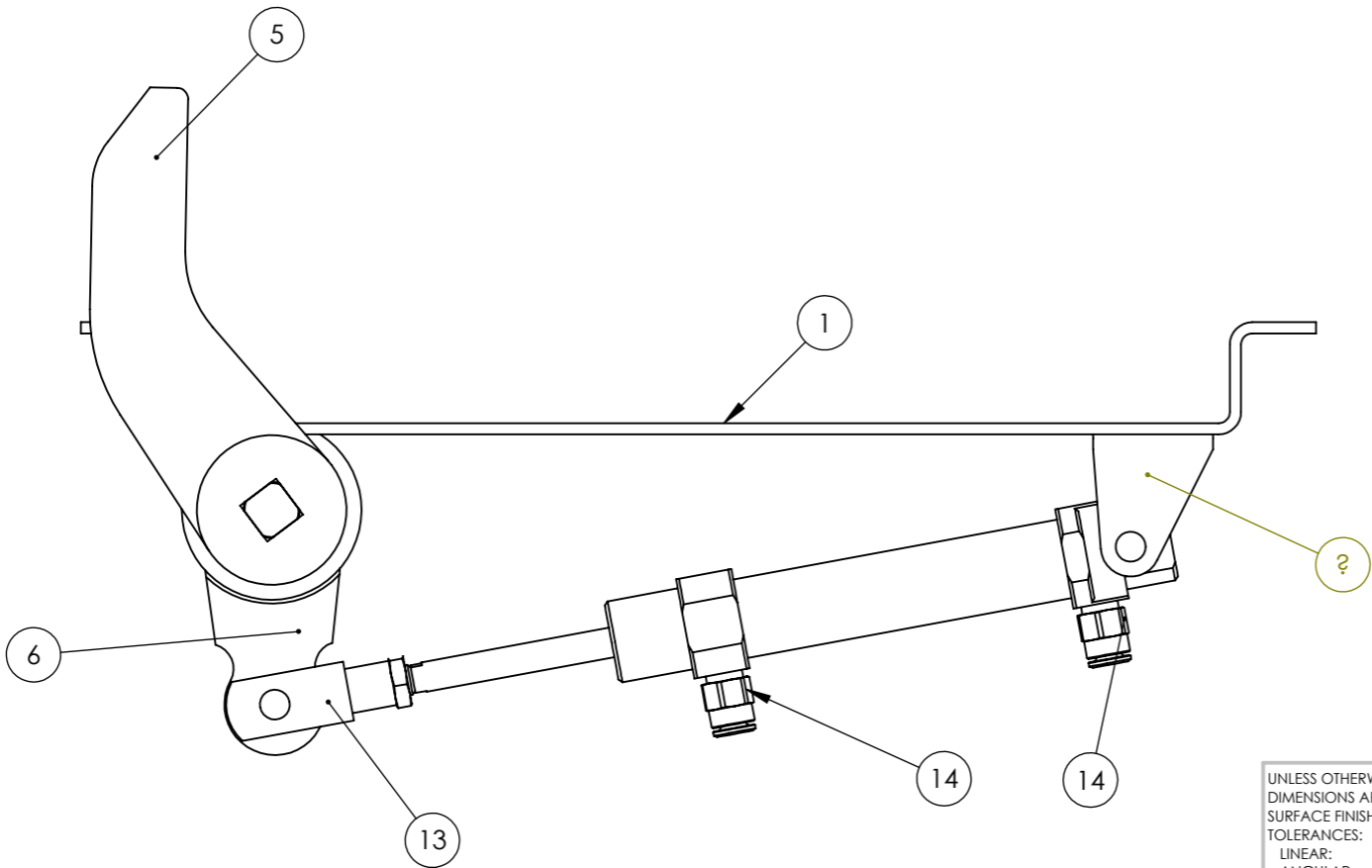
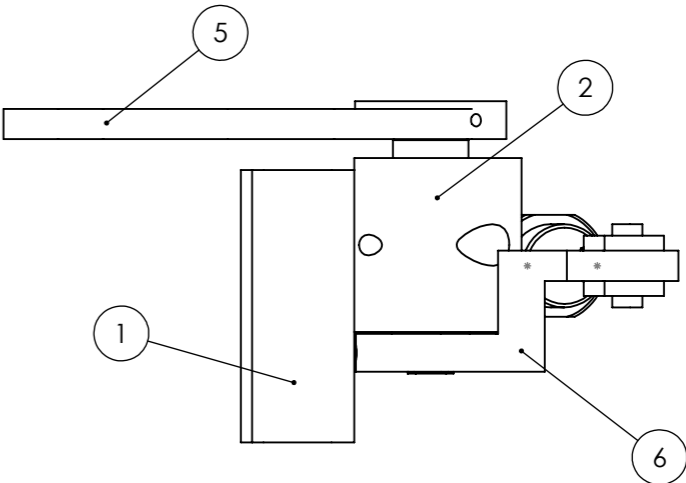
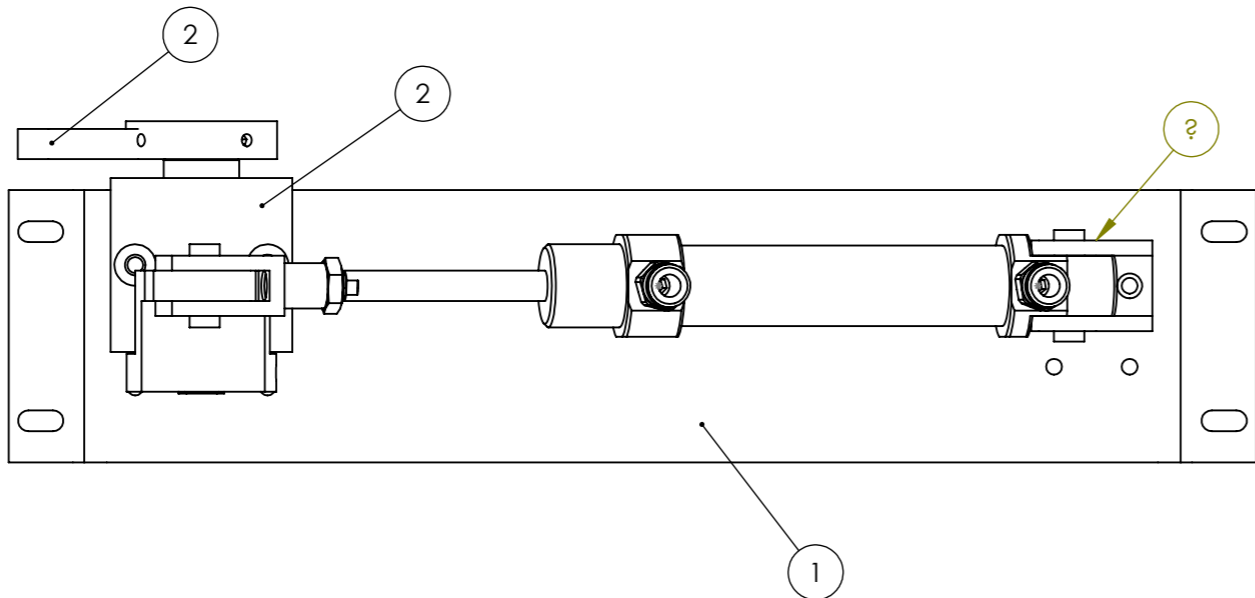

1 Conjunto

ITEM NO.	PART NUMBER	QTY.
1	Base_Montagem_P	1
2	CorpoPusher_Dto_Peq	1
3	RM_8020_M_50_Magnetic_Piston_0_B_0_	1
4	QM_8020_44	1

UNLESS OTHERWISE SPECIFIED: DIMENSIONS ARE IN MILLIMETERS SURFACE FINISH: TOLERANCES: LINEAR: ANGULAR:		FINISH:	DEBURR AND BREAK SHARP EDGES	
DRAWN Pamiés Teixeira		SIGNATURE	DATE	
CHK'D				
APPV'D				
MFG				
Q.A				
		MATERIAL:		
		WEIGHT:		
		DO NOT SCALE DRAWING		REVISION
		Last saved		11/05/2023
		TITLE: Conunto Direito Peq Extended		
		DWG NO. PD-002		A3
		SCALE:1:2		SHEET 1 OF 1

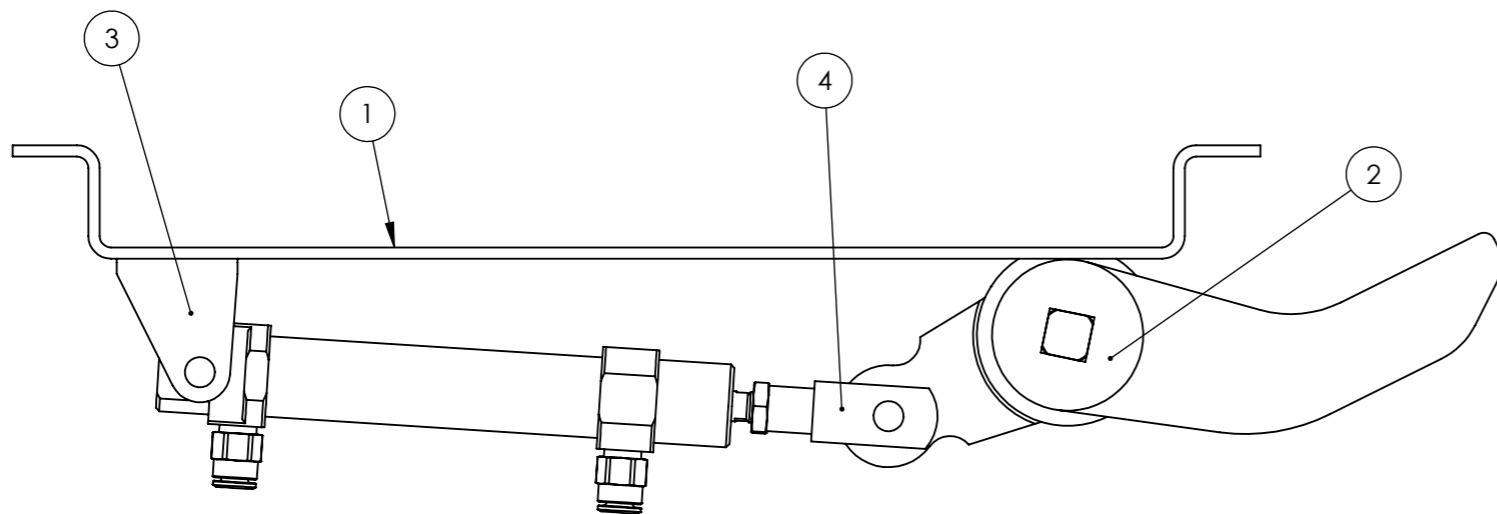
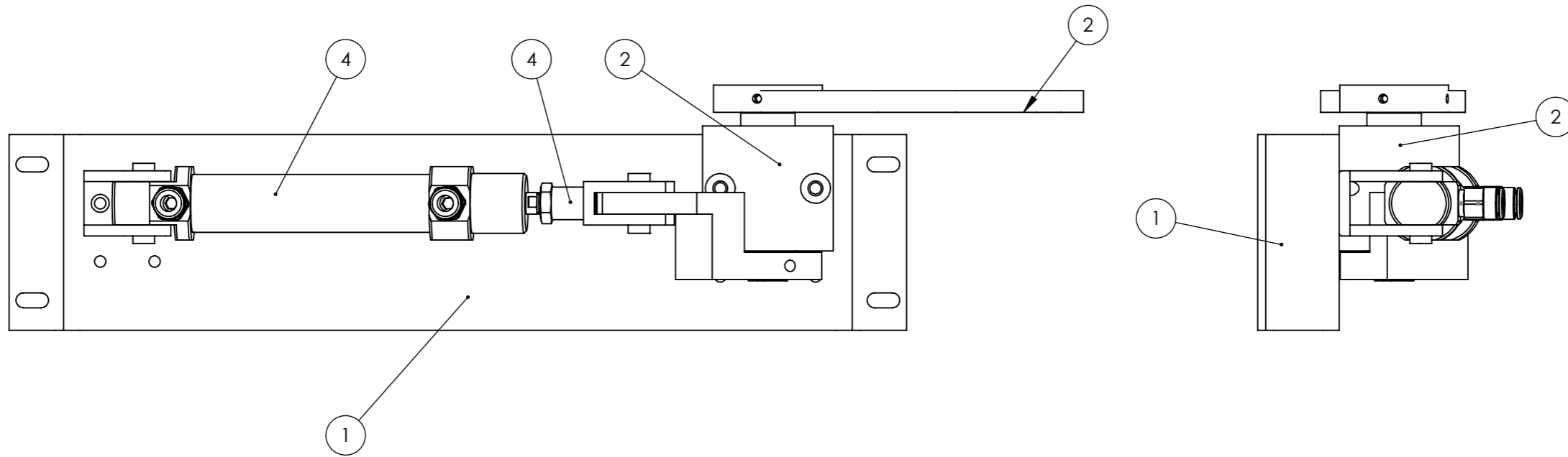

1 Conjunto

ITEM NO.	PART NUMBER	QTY.
1	Base_Montagem_P	1
2	CorpoPusher_Esq_Peq	1
3	QM_8020_44_20_CA	1
4	RM_8020_M_50_Magnetic_Piston_0_B_0_	1

UNLESS OTHERWISE SPECIFIED: DIMENSIONS ARE IN MILLIMETERS SURFACE FINISH: TOLERANCES: LINEAR: ANGULAR:			FINISH:		DEBURR AND BREAK SHARP EDGES		DO NOT SCALE DRAWING		REVISION		
							Last saved		11/05/2023		
							TITLE: Cojunto Esquerdo Peq Default				
DRAWN			NAME		SIGNATURE		DATE		DWG NO.		
CHK'D									A3		
APPV'D											
MFG											
Q.A							MATERIAL:				
							WEIGHT:		SCALE:1:5		
									SHEET 1 OF 1		

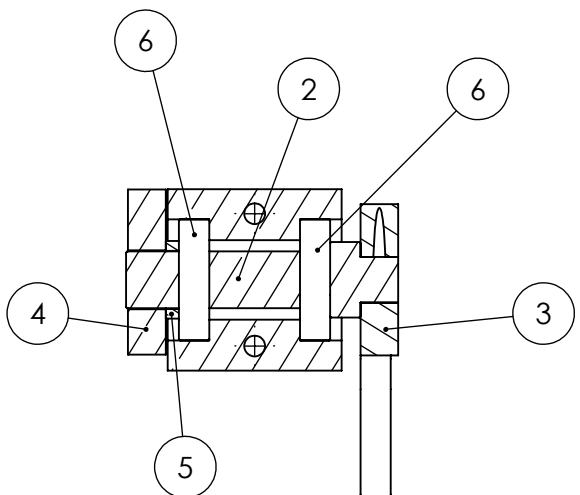
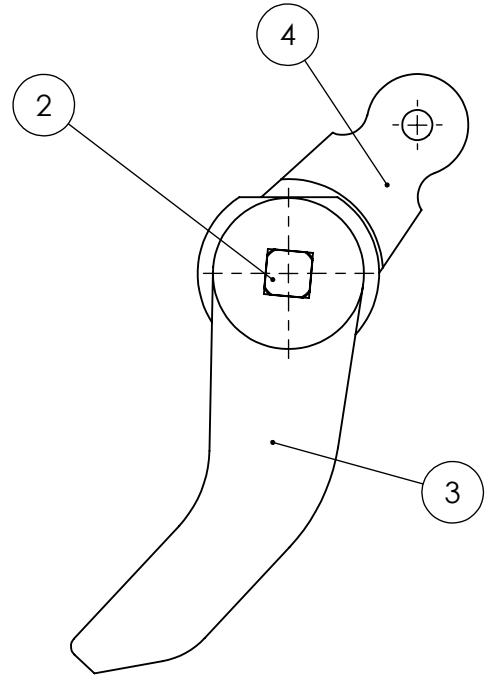
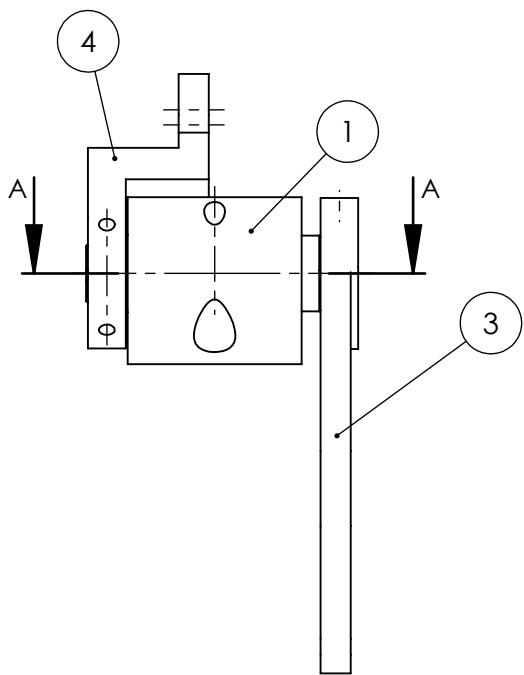

SECTION A-A

1 Conjunto

ITEM NO.	PART NUMBER	QTY.
1	Cubo_V3	1
2	Veio_P-Dto	1
3	BielaMandada_Peq_Mod	1
4	BielaMandante	1
5	Espaçador	1
6	SKF - 16002 - 12,SI,NC,12_68	2

UNLESS OTHERWISE SPECIFIED:
 DIMENSIONS ARE IN MILLIMETERS
 SURFACE FINISH:
 TOLERANCES:
 LINEAR:
 ANGULAR:

FINISH:

DEBURR AND
 BREAK SHARP
 EDGES

DO NOT SCALE DRAWING

REVISION

Last saved

11/05/2023

	NAME	SIGNATURE	DATE
DRAWN			
CHK'D			
APPV'D			
MFG			
Q.A			

TITLE: **Corpo Pusher Dto**

MATERIAL: _____ DWG NO. _____

WEIGHT: _____ SCALE:1:2 SHEET 1 OF 1

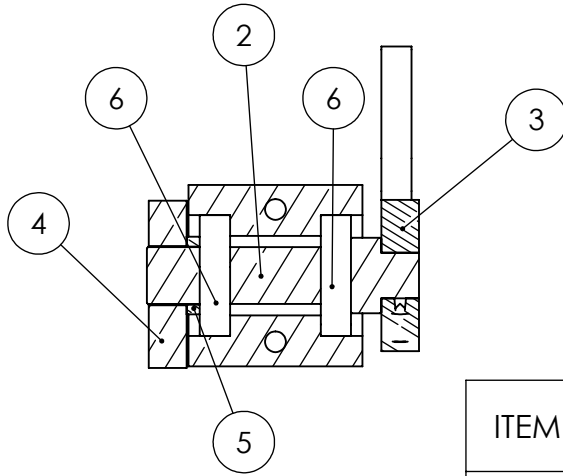
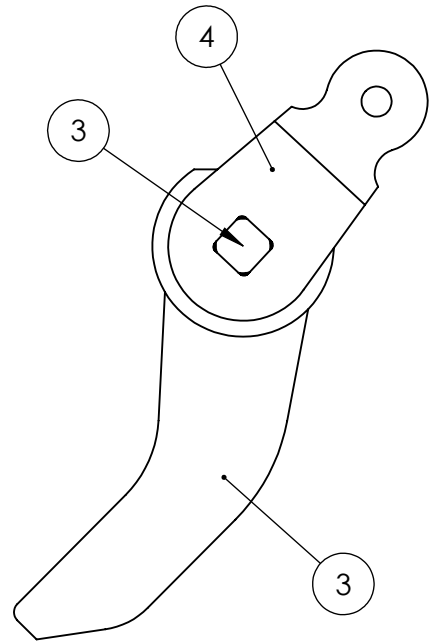
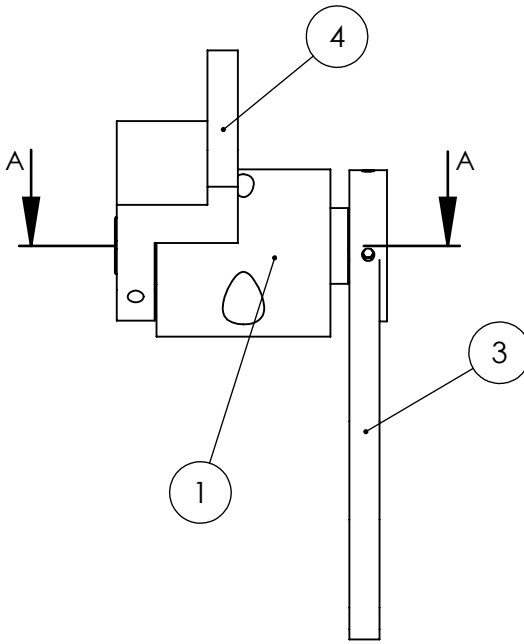

1 Conjunto

ITEM NO.	PART NUMBER	QTY.
1	Cubo_V3	1
2	Veio_P-Esq	1
3	BielaMandada_Peq_Mod	1
4	BielaMandante	1
5	Espaçador	1
6	SKF - 16002 - 12,SI,NC,12_68	2
7	ISO 4028 - M5 x 12-N	1
8	ISO 4028 - M5 x 10-N	1
9	ISO 4027 - M5 x 10-N	1

UNLESS OTHERWISE SPECIFIED:
DIMENSIONS ARE IN MILLIMETERS
SURFACE FINISH:
TOLERANCES:
LINEAR:
ANGULAR:

FINISH:

DEBURR AND
BREAK SHARP
EDGES

DO NOT SCALE DRAWING

REVISION

Last saved

11/05/2023

	NAME	SIGNATURE	DATE
DRAWN			
CHK'D			
APPV'D			
MFG			
Q.A			

TITLE:

Corpo Pusher Esq-Peq

MATERIAL:

DWG NO.

A4

WEIGHT:

SCALE:1:2

SHEET 1 OF 1

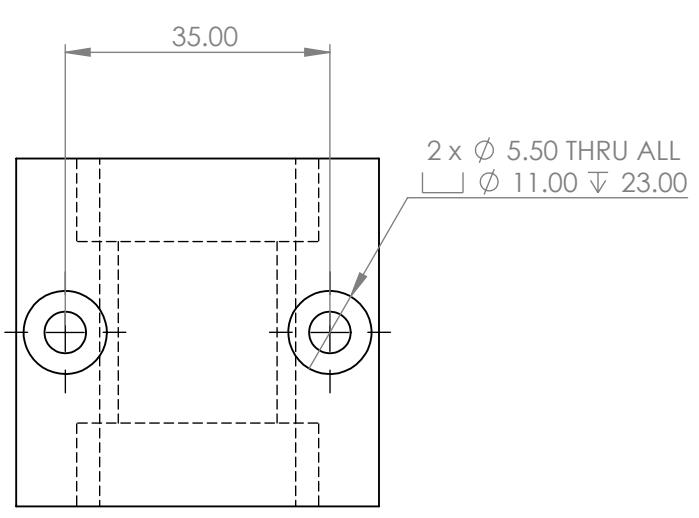
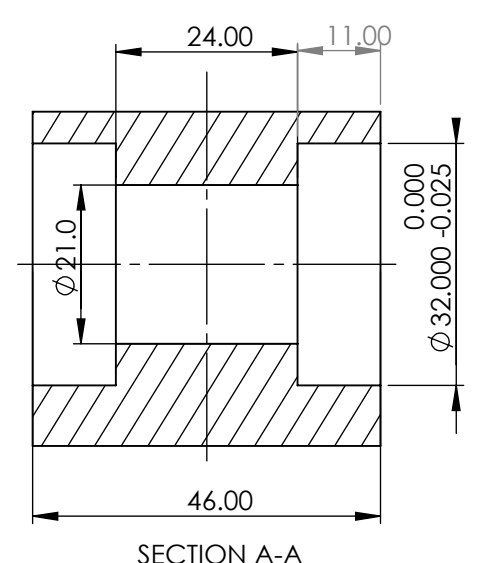
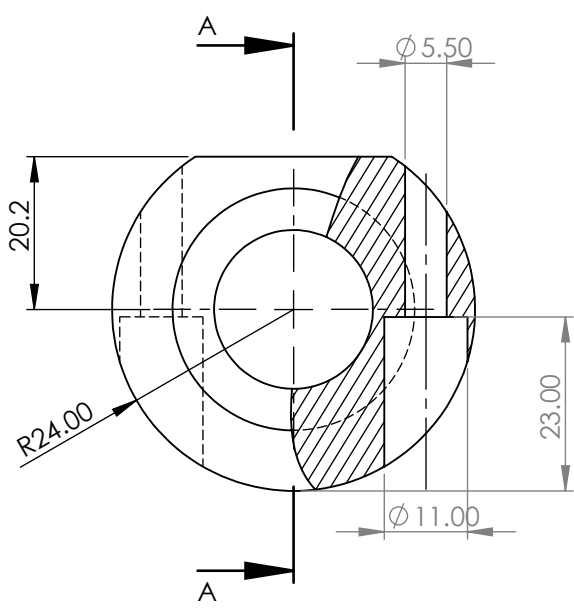

8 Peças p/ Mesa Grande
4 Peças p/Mesa Pequena

UNLESS OTHERWISE SPECIFIED: DIMENSIONS ARE IN MILLIMETERS SURFACE FINISH: TOLERANCES: LINEAR: ANGULAR:			FINISH:	DEBURR AND BREAK SHARP EDGES	DO NOT SCALE DRAWING	REVISION
					Last saved	10/05/2023
NAME	SIGNATURE	DATE	TITLE: Cubo			
DRAWN Pamies Teixeira						
CHK'D						
APPV'D						
MFG						
Q.A			MATERIAL: 2024-T3	DWG NO. CB-01	A4	
			WEIGHT:	SCALE:1:1	SHEET 1 OF 1	

4 3 2 1

F

F

E

E

D

D

C

C

B

B

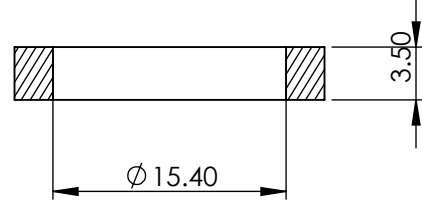
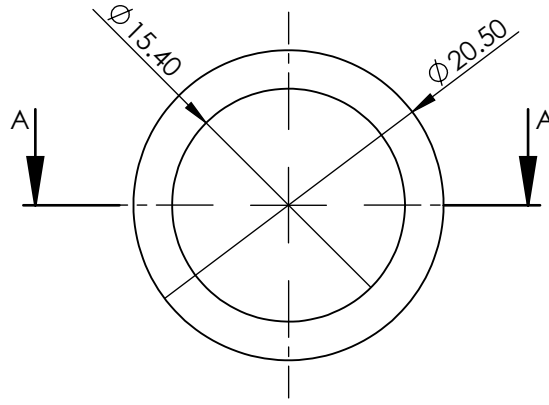

SECTION A-A

UNLESS OTHERWISE SPECIFIED:
 DIMENSIONS ARE IN MILLIMETERS
 SURFACE FINISH:
 TOLERANCES:
 LINEAR:
 ANGULAR:

FINISH:

DEBURR AND
 BREAK SHARP
 EDGES

DO NOT SCALE DRAWING

REVISION

Last saved 09/05/2023

	NAME	SIGNATURE	DATE
DRAWN			
CHK'D			
APPV'D			
MFG			
Q.A			

TITLE:	Espaçador	
MATERIAL:	Material <not specified>	DWG NO. E-01
WEIGHT:		SCALE:2:1
		SHEET 1 OF 1

A

A

4 3 2 1

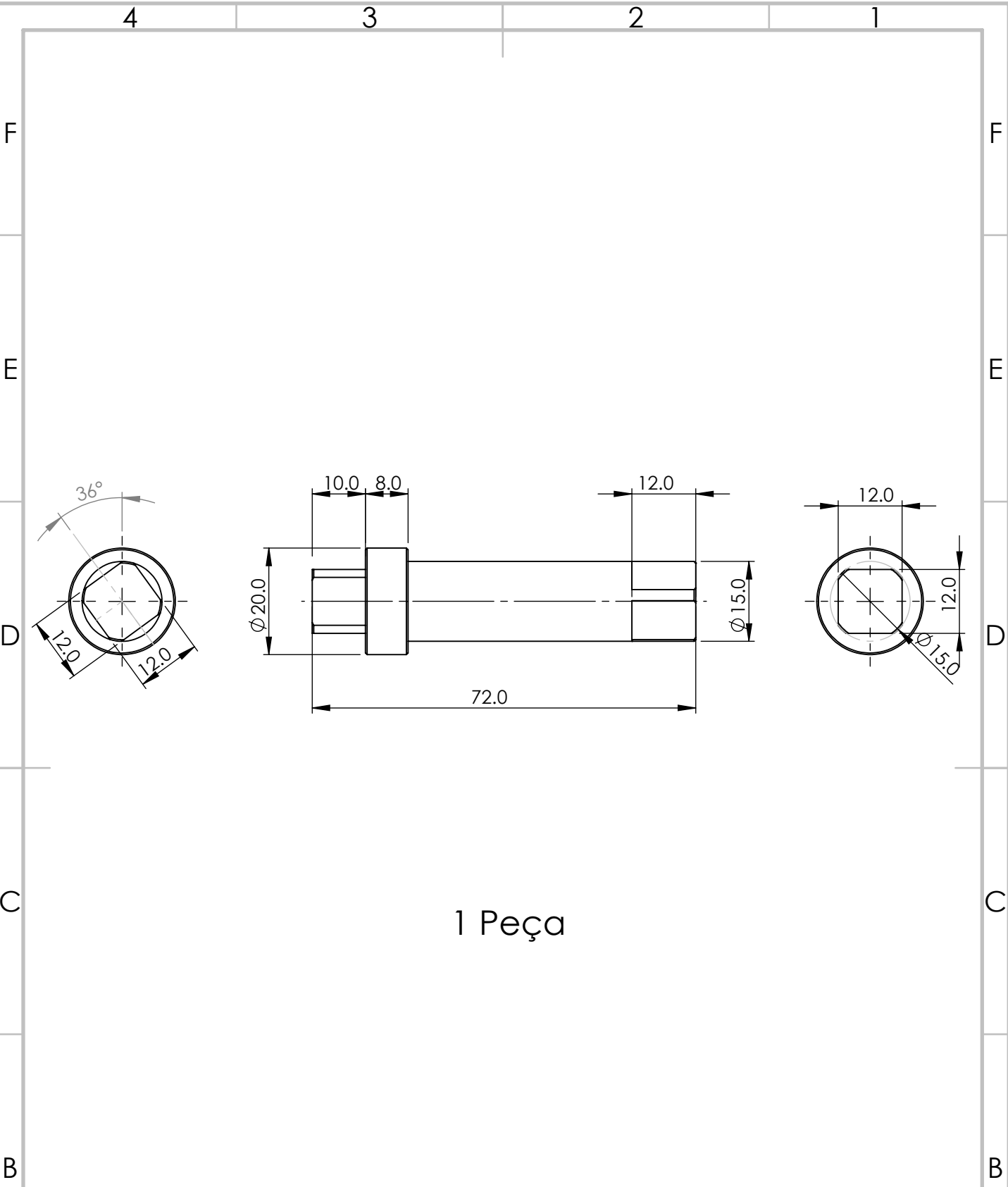

1 Peça

UNLESS OTHERWISE SPECIFIED:
 DIMENSIONS ARE IN MILLIMETERS
 SURFACE FINISH:
 TOLERANCES:
 LINEAR:
 ANGULAR:

FINISH:

DEBURR AND
 BREAK SHARP
 EDGES

DO NOT SCALE DRAWING

REVISION

Last saved 11/05/2023

	NAME	SIGNATURE	DATE
DRAWN	Pamies Teixeira		
CHK'D			
APPV'D			
MFG			
Q.A			

TITLE:		Veio P Dto	
MATERIAL:		2024 Alloy	
DWG NO.:		V-02	
WEIGHT:		SCALE:1:1	
		SHEET 1 OF 1	

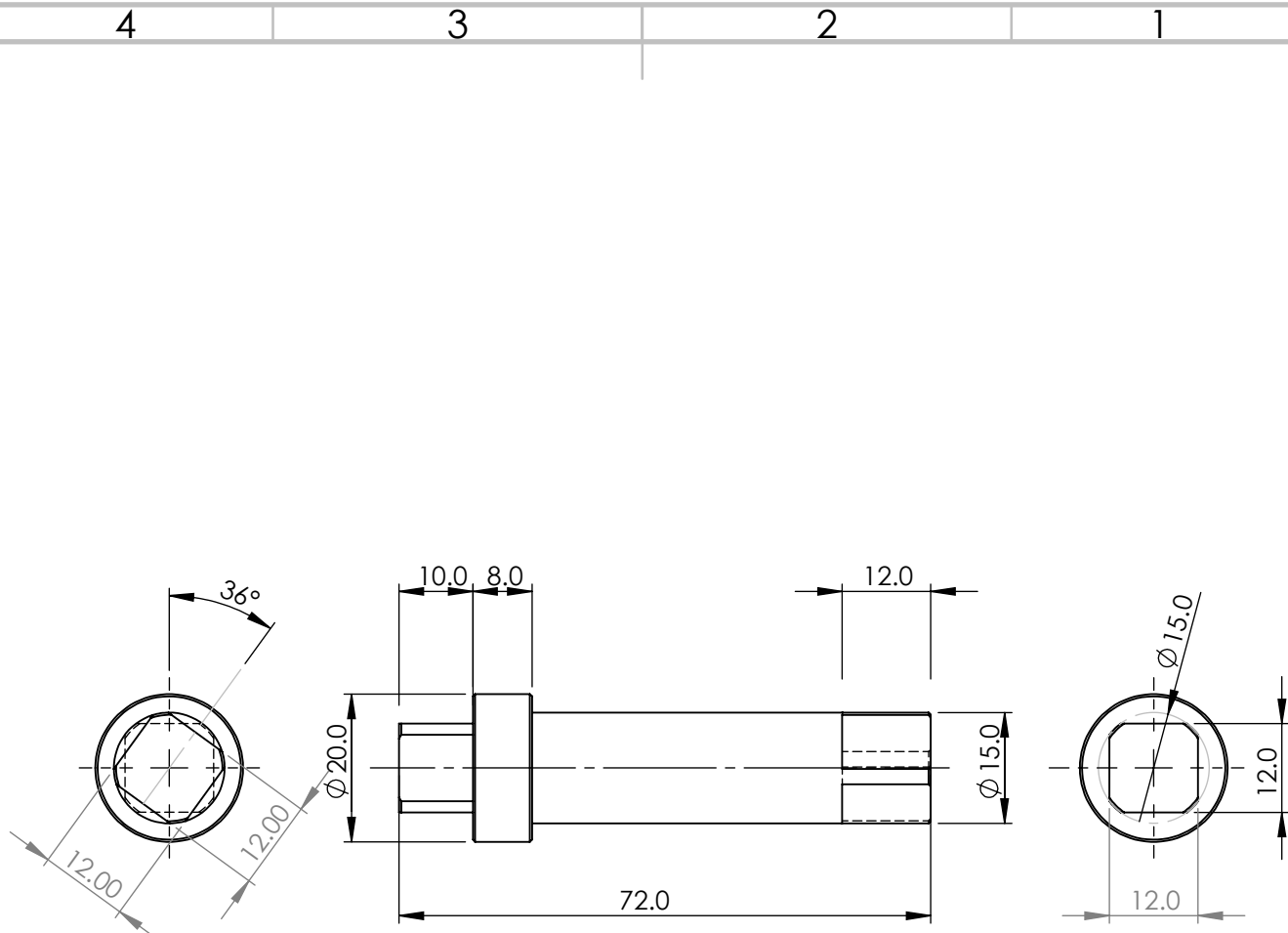

1 Peça

UNLESS OTHERWISE SPECIFIED: DIMENSIONS ARE IN MILLIMETERS SURFACE FINISH: TOLERANCES: LINEAR: ANGULAR:			FINISH:	DEBURR AND BREAK SHARP EDGES	DO NOT SCALE DRAWING	REVISION
					Last saved	11/05/2023
NAME	SIGNATURE	DATE	TITLE:			
DRAWN Pamies Teixeira			Veio_P Esq			
CHK'D						
APPV'D						
MFG						
Q.A			MATERIAL:	DWG NO.	A4	
			2024 Alloy	V-02		
			WEIGHT:	SCALE:1:1	SHEET 1 OF 1	

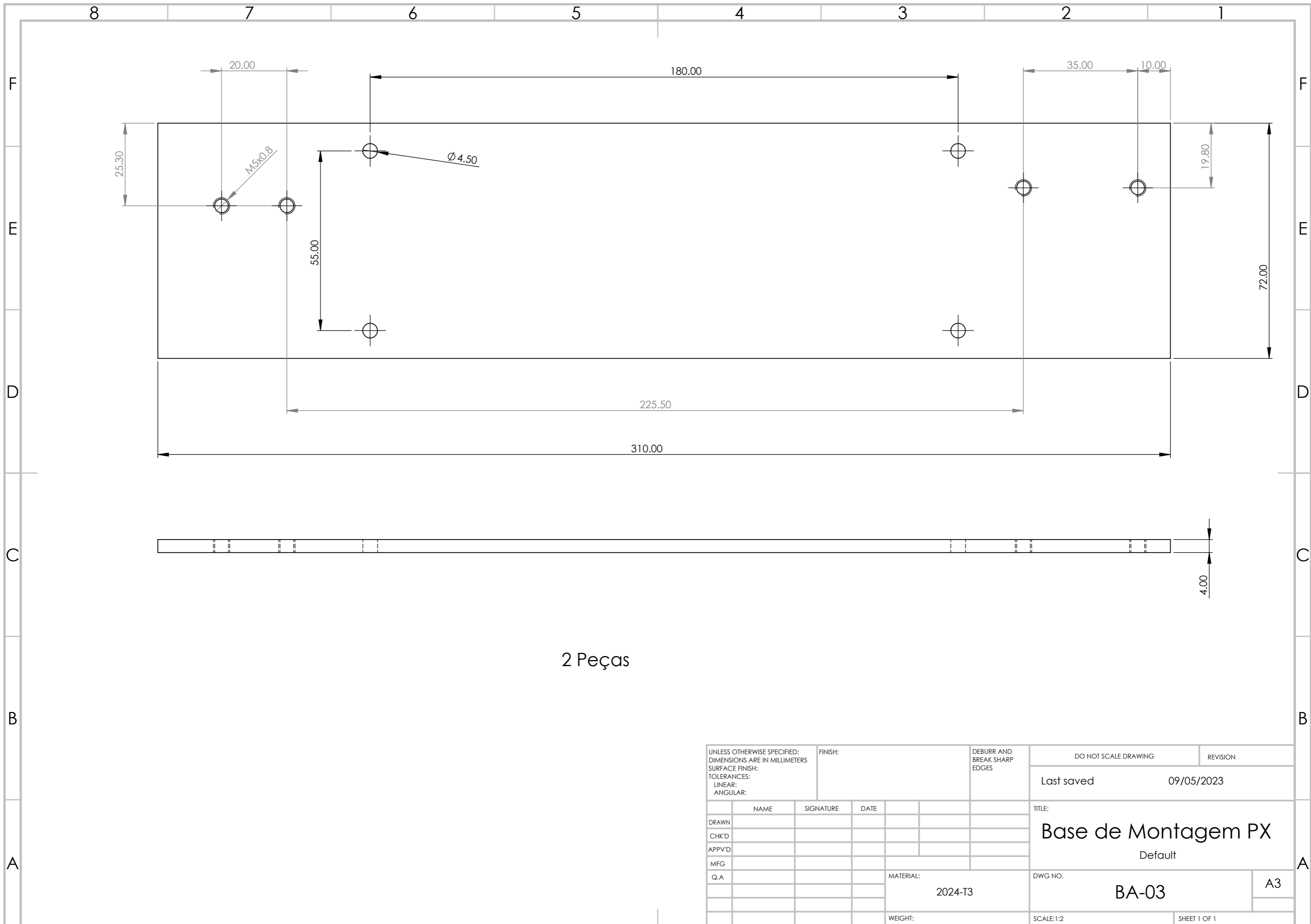

2 Peças

UNLESS OTHERWISE SPECIFIED: DIMENSIONS ARE IN MILLIMETERS				FINISH:		DEBURR AND BREAK SHARP EDGES		DO NOT SCALE DRAWING		REVISION	
SURFACE FINISH:								Last saved		09/05/2023	
TOLERANCES:								TITLE:			
LINEAR:								Base de Montagem PX			
ANGULAR:								Default			
DRAWN		NAME		SIGNATURE		DATE		DWG NO.		A3	
CHK'D								2024-T3		BA-03	
APPV'D								SCALE:1:2		SHEET 1 OF 1	
MFG								WEIGHT:			
Q.A											

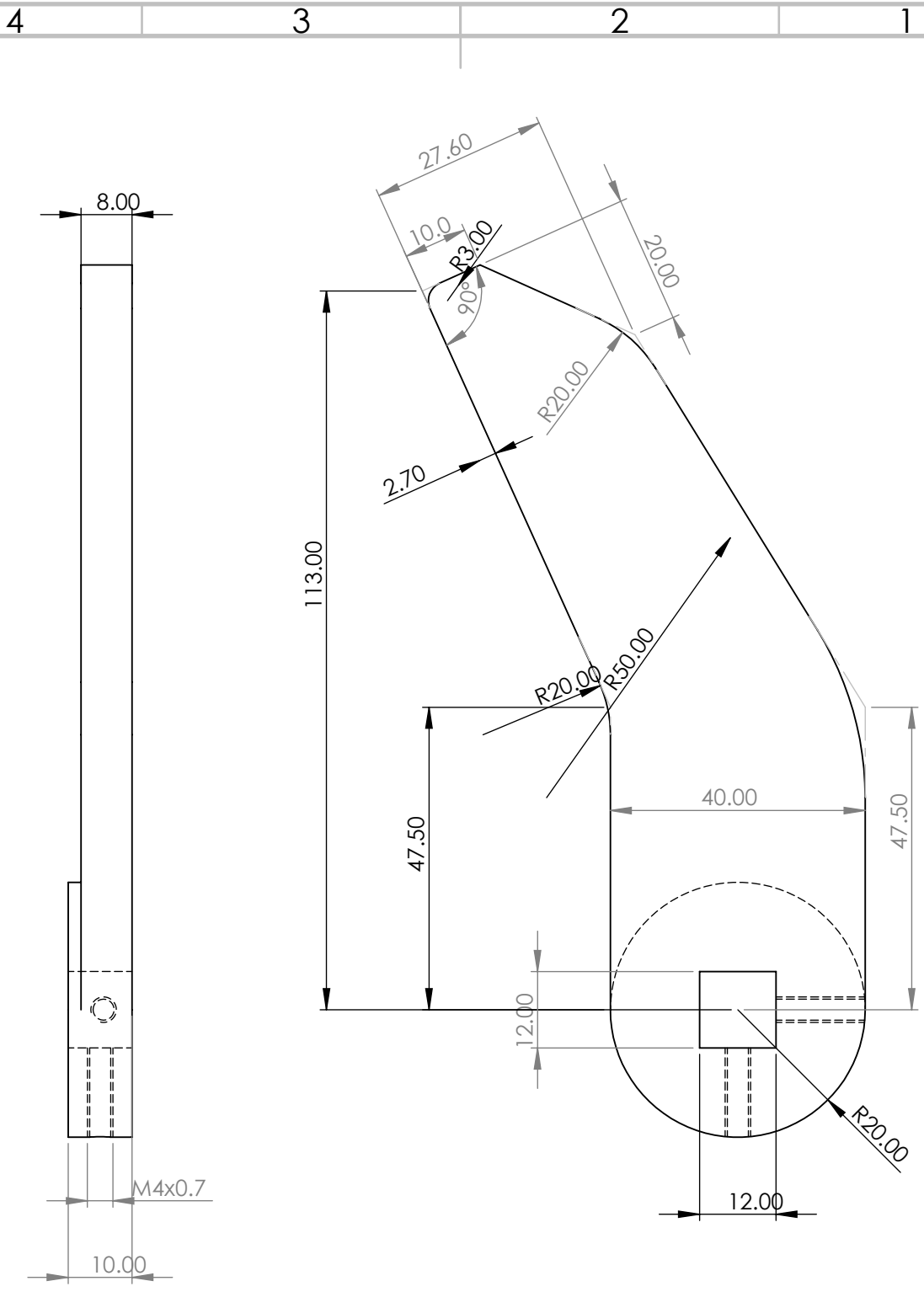

UNLESS OTHERWISE SPECIFIED:
 DIMENSIONS ARE IN MILLIMETERS
 SURFACE FINISH:
 TOLERANCES:
 LINEAR:
 ANGULAR:

FINISH:

DEBURR AND
 BREAK SHARP
 EDGES

DO NOT SCALE DRAWING

REVISION

Last saved 09/05/2023

	NAME	SIGNATURE	DATE
DRAWN	Pamies Teixeira		
CHK'D			
APPV'D			
MFG			
Q.A			

TITLE:
Biela Mandada X
 Direita

DWG NO. **BM-03**

SCALE:1:1

SHEET 1 OF 1

MATERIAL:
 2024-T3

WEIGHT:

A4

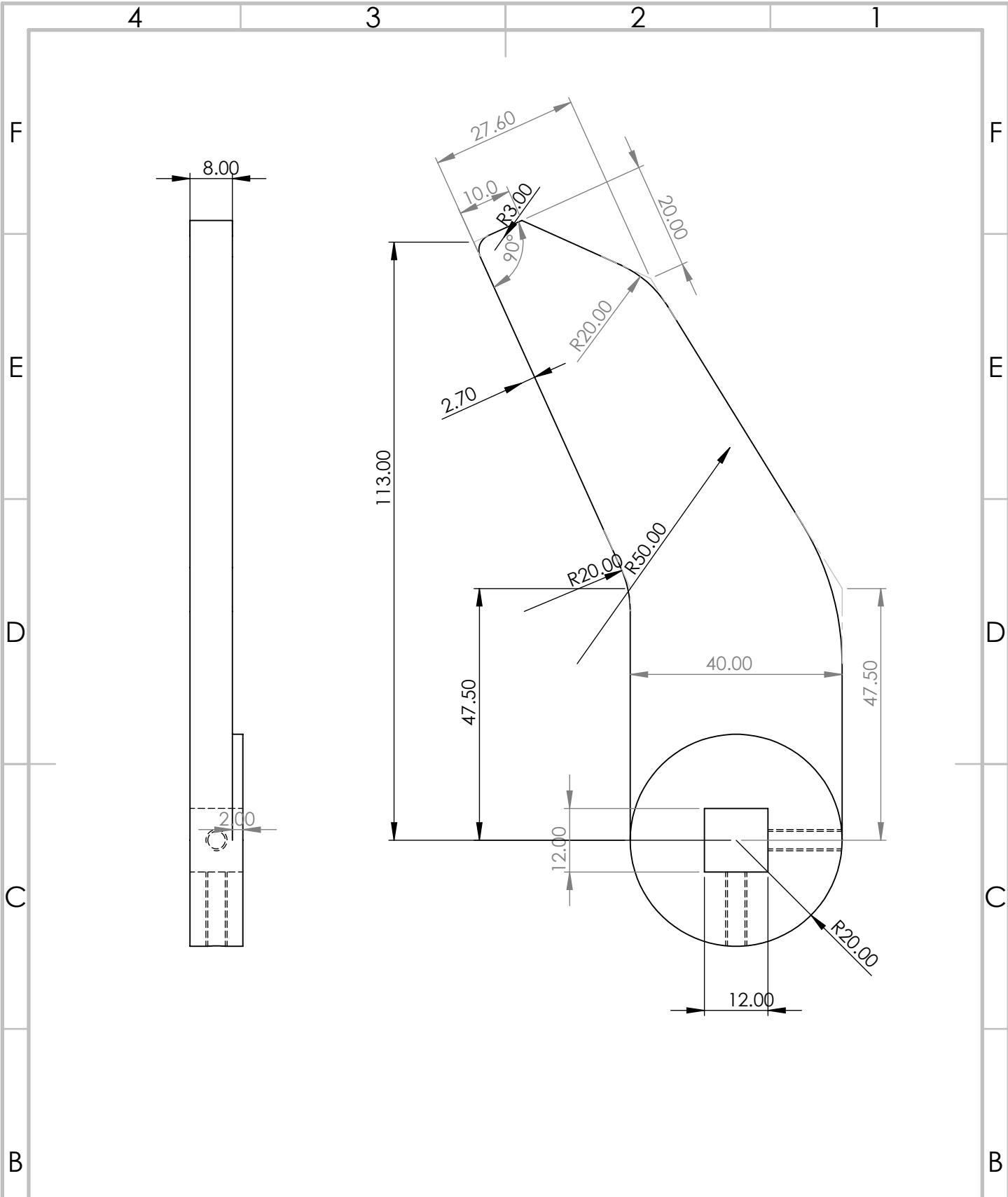

UNLESS OTHERWISE SPECIFIED:
 DIMENSIONS ARE IN MILLIMETERS
 SURFACE FINISH:
 TOLERANCES:
 LINEAR:
 ANGULAR:

FINISH:

DEBURR AND
 BREAK SHARP
 EDGES

DO NOT SCALE DRAWING

REVISION

Last saved 09/05/2023

	NAME	SIGNATURE	DATE
DRAWN	Pamies Teixeira		
CHK'D			
APPV'D			
MFG			
Q.A			

TITLE:
Biela Mandada X
Esquerda

DWG NO. **BM-03**

MATERIAL:
 Material <not specified>

SCALE:1:1

SHEET 1 OF 1

A4

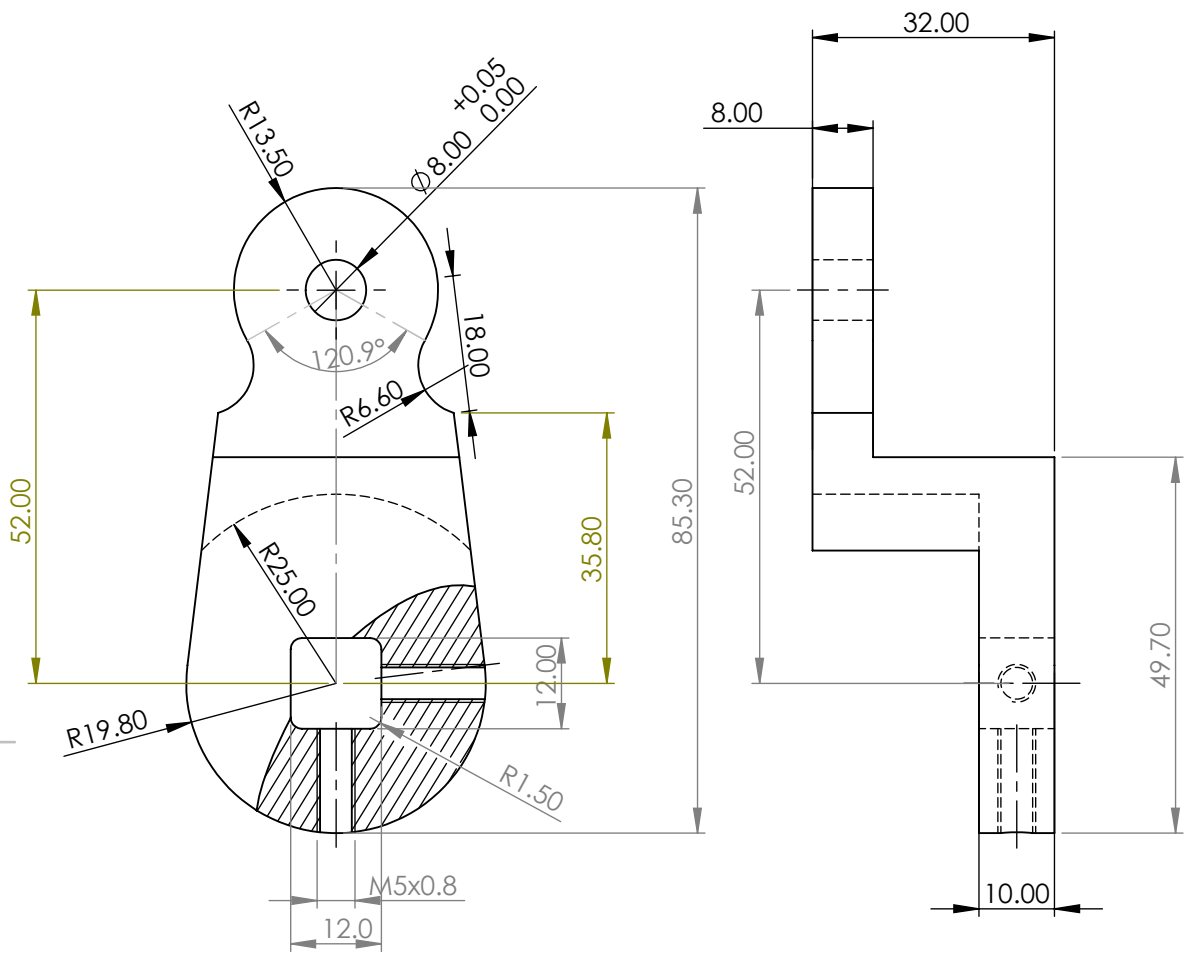

8 Peças p/ Mesa Grande
4 Peças p/ Mesa Pequena

UNLESS OTHERWISE SPECIFIED:
DIMENSIONS ARE IN MILLIMETERS
SURFACE FINISH:
TOLERANCES:
LINEAR:
ANGULAR:

FINISH:

DEBURR AND
BREAK SHARP
EDGES

DO NOT SCALE DRAWING

REVISION

Last saved

11/05/2023

	NAME	SIGNATURE	DATE
DRAWN	Pamies Teixeira		
CHK'D			
APPV'D			
MFG			
Q.A			

TITLE:		Biela Mandante	
MATERIAL:		2024-T3	
DWG NO.:		BD-01	
WEIGHT:		SCALE:1:1	
		SHEET 1 OF 1	

A4

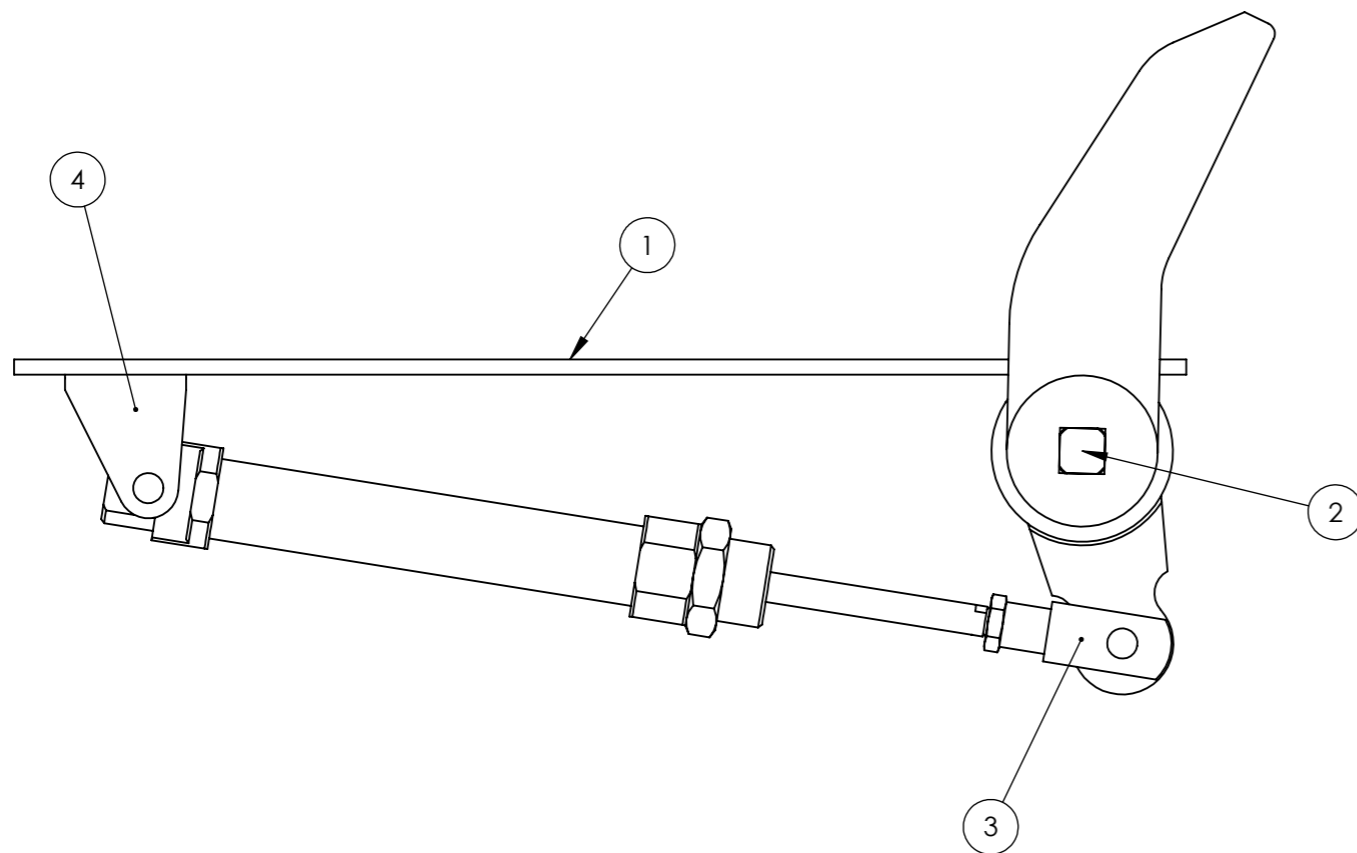
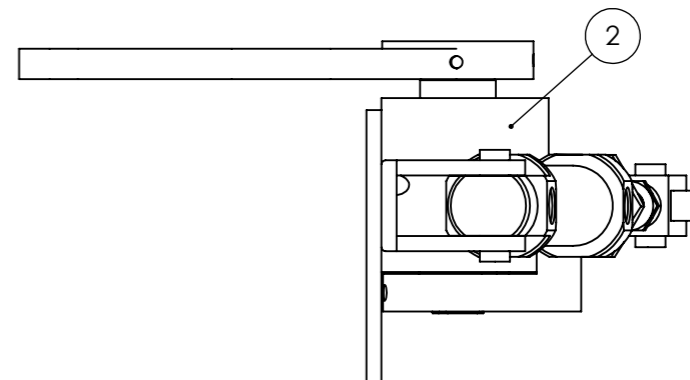
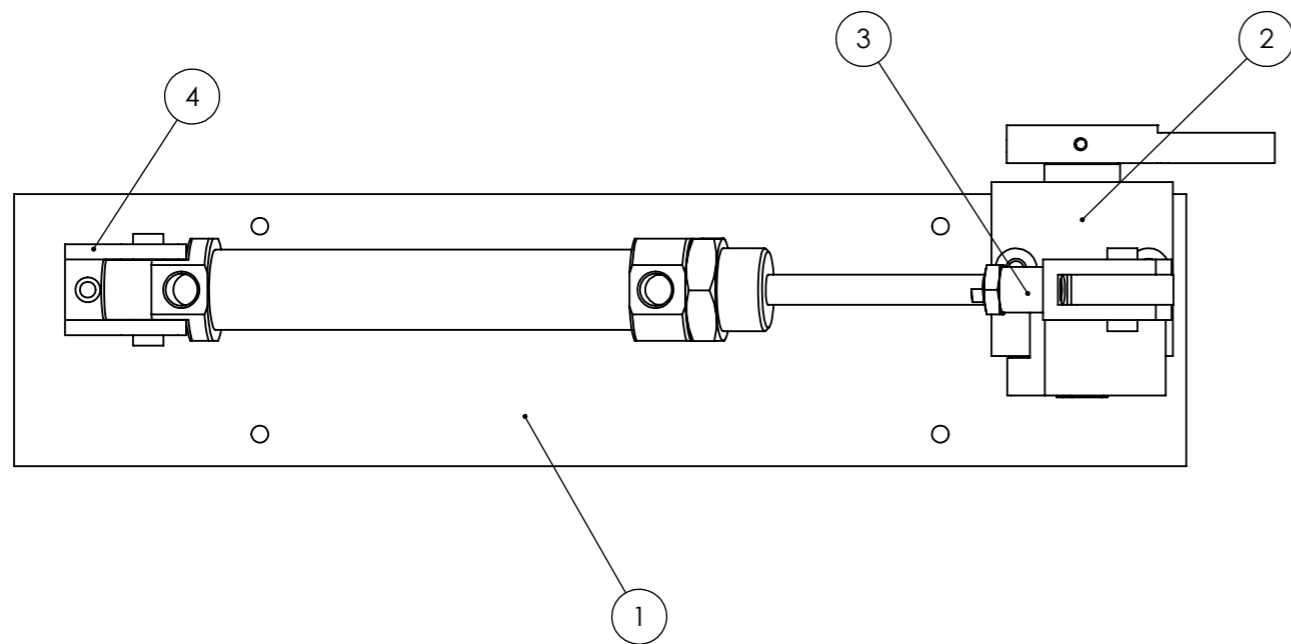

1 Conjunto

ITEM NO.	PART NUMBER	QTY.
1	Base_Montagem_PX	1
2	CorpoPusher_Dto_X	1
3	RM_8020_M_75+QM_8020_38+M_P19409+M_P13615(Magnetic Piston,0,B,0,)	1
4	QM_8020_44_20_CA	1

UNLESS OTHERWISE SPECIFIED: DIMENSIONS ARE IN MILLIMETERS SURFACE FINISH: TOLERANCES: LINEAR: ANGULAR:			FINISH:		DEBURR AND BREAK SHARP EDGES		DO NOT SCALE DRAWING		REVISION	
							Last saved		11/05/2023	
							TITLE:		Conjunto Dto PX	
									Default	
DRAWN Pamiés Teixeira			SIGNATURE		DATE		DWG NO.		PD-003	
CHK'D							SCALE:1:5		SHEET 1 OF 1	
APPV'D							WEIGHT:			
MFG										
Q.A										

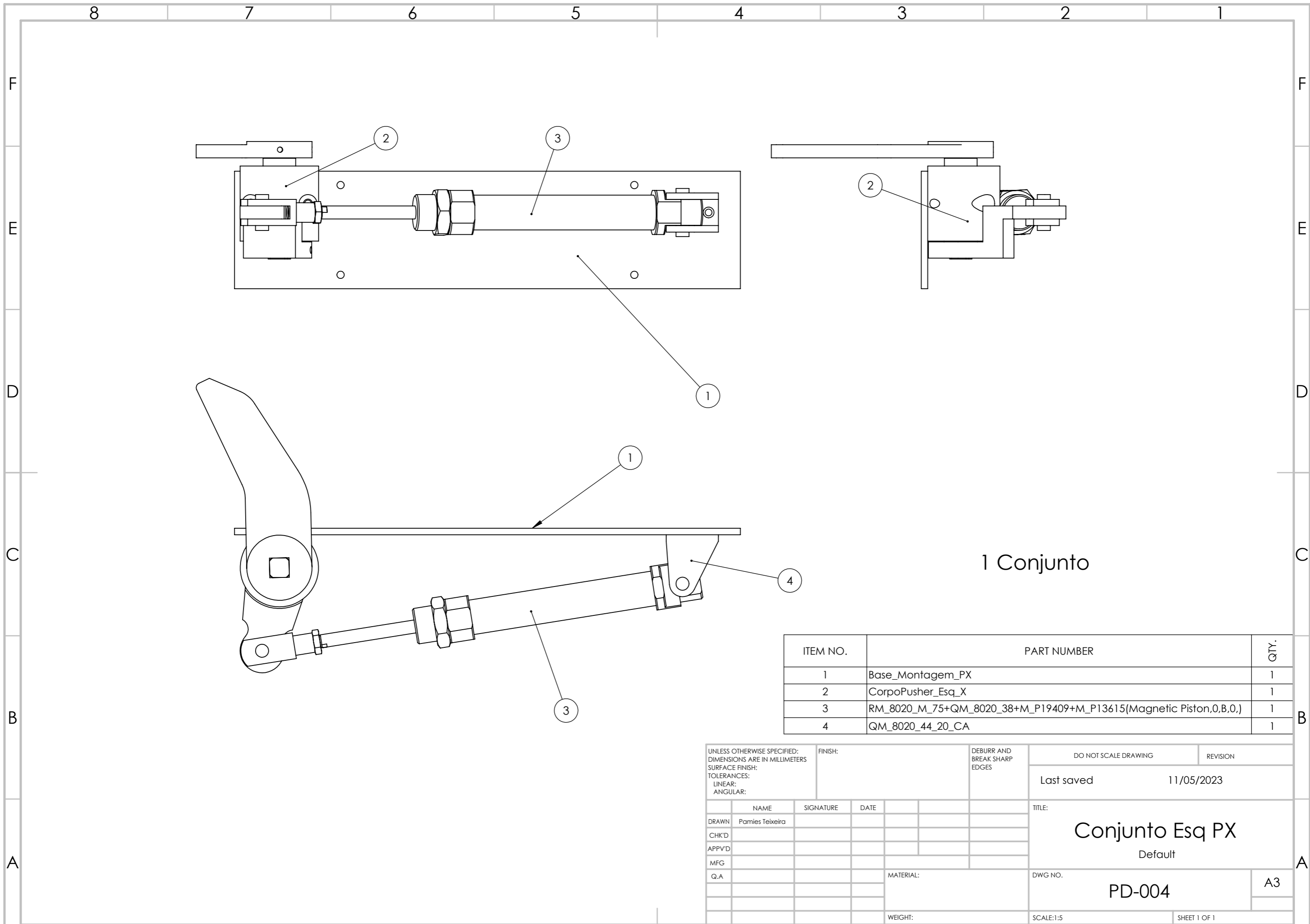

1 Conjunto

ITEM NO.	PART NUMBER	QTY.
1	Base_Montagem_PX	1
2	CorpoPusher_Esq_X	1
3	RM_8020_M_75+QM_8020_38+M_P19409+M_P13615(Magnetic Piston,0,B,0,)	1
4	QM_8020_44_20_CA	1

UNLESS OTHERWISE SPECIFIED: DIMENSIONS ARE IN MILLIMETERS SURFACE FINISH: TOLERANCES: LINEAR: ANGULAR:			FINISH:		DEBURR AND BREAK SHARP EDGES		DO NOT SCALE DRAWING		REVISION	
							Last saved		11/05/2023	
							TITLE:		Conjunto Esq PX	
							Default			
DRAWN Pamies Teixeira			SIGNATURE		DATE		DWG NO.		PD-004	
CHK'D							SCALE:1:5		SHEET 1 OF 1	
APPV'D							WEIGHT:			
MFG							MATERIAL:			
Q.A									A3	

4 3 2 1

F

F

E

E

D

D

C

C

B

B

A

A

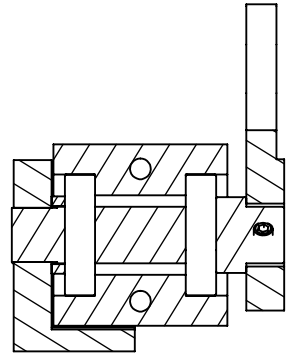
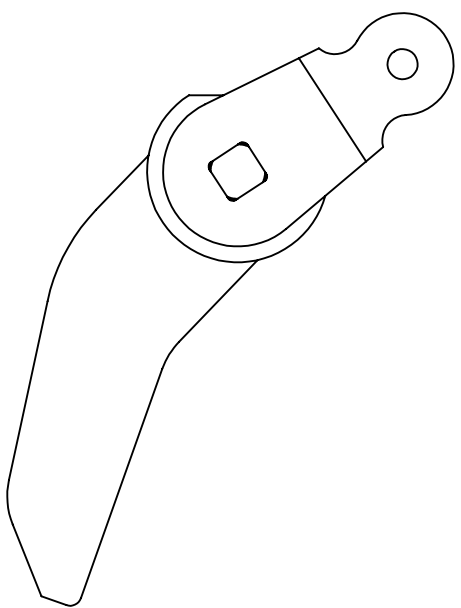
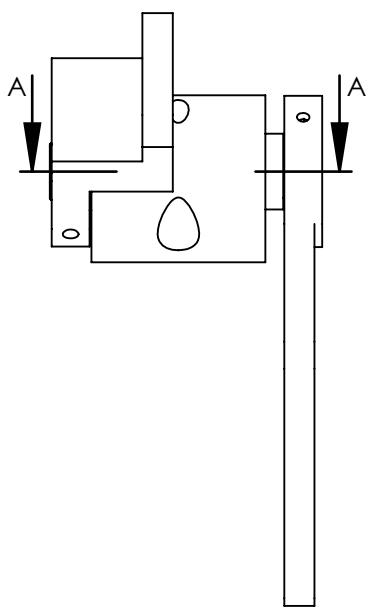

SECTION A-A

ITEM NO.	PART NUMBER	QTY.
1	Cubo_V3	1
2	Veio_PX-Dto	1
3	BielaMandada_Peq_X	1
4	BielaMandante	1
5	Espaçador	1
6	SKF - 16002 - 12,SI,NC,12_68	2

UNLESS OTHERWISE SPECIFIED:
 DIMENSIONS ARE IN MILLIMETERS
 SURFACE FINISH:
 TOLERANCES:
 LINEAR:
 ANGULAR:

FINISH:

DEBURR AND
 BREAK SHARP
 EDGES

DO NOT SCALE DRAWING REVISION
 Last saved 11/05/2023

	NAME	SIGNATURE	DATE
DRAWN			
CHK'D			
APPV'D			
MFG			
Q.A			

TITLE:
Corpo Pusher Dto

MATERIAL: DWG NO. A4

WEIGHT: SCALE:1:2 SHEET 1 OF 1

4 3 2 1

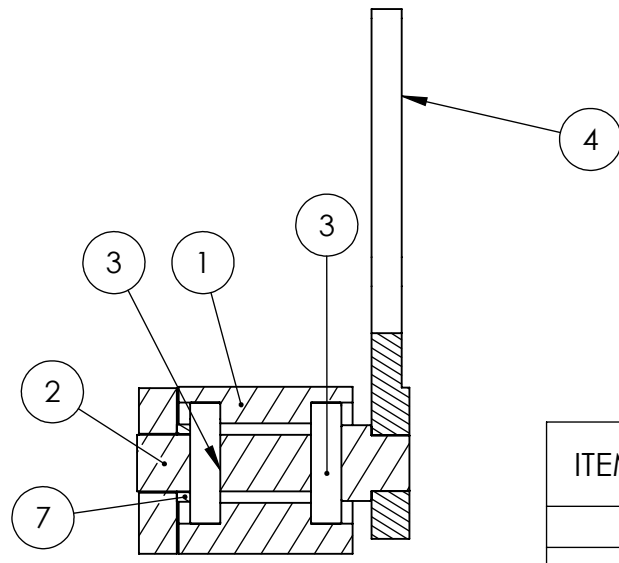
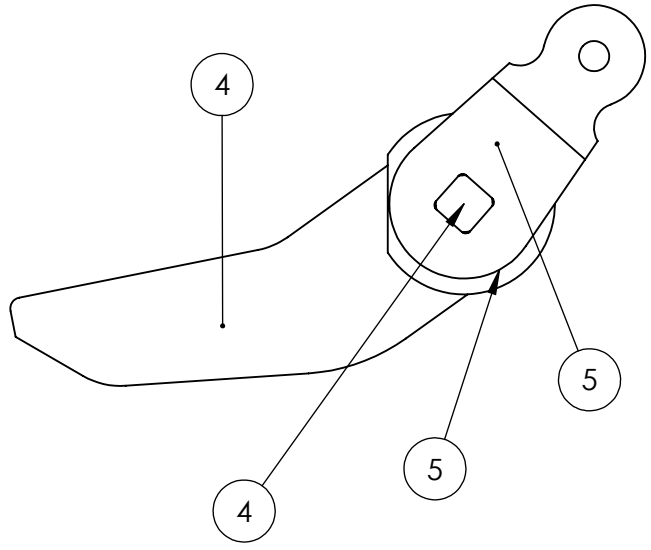
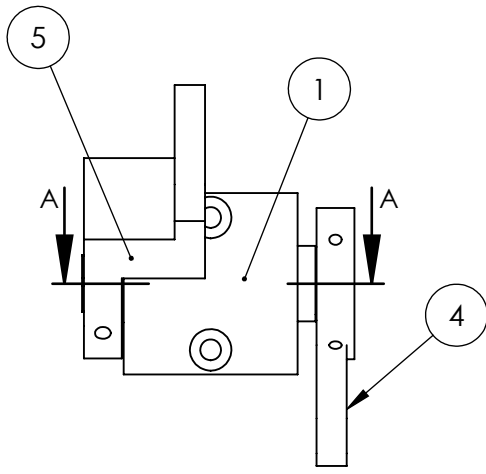

1 Conjunto

ITEM NO.	PART NUMBER	QTY.
1	Cubo_V3	1
2	Veio_PX-Esq	1
3	SKF - 16002 - 12,SI,NC,12_68	2
4	BielaMandada_Peq_X	1
5	BielaMandante	1
6	ISO 4028 - M5 x 10-N	1
7	Espaçador	1

UNLESS OTHERWISE SPECIFIED:
 DIMENSIONS ARE IN MILLIMETERS
 SURFACE FINISH:
 TOLERANCES:
 LINEAR:
 ANGULAR:

FINISH:

 DEBURR AND
 BREAK SHARP
 EDGES

DO NOT SCALE DRAWING
 REVISION
 Last saved
 11/05/2023

NAME	SIGNATURE	DATE
DRAWN		
CHK'D		
APPV'D		
MFG		
Q.A		

TITLE:
Corpo Pusher Esquerdo

 DWG NO.
 A4

 SCALE:1:2
 SHEET 1 OF 1

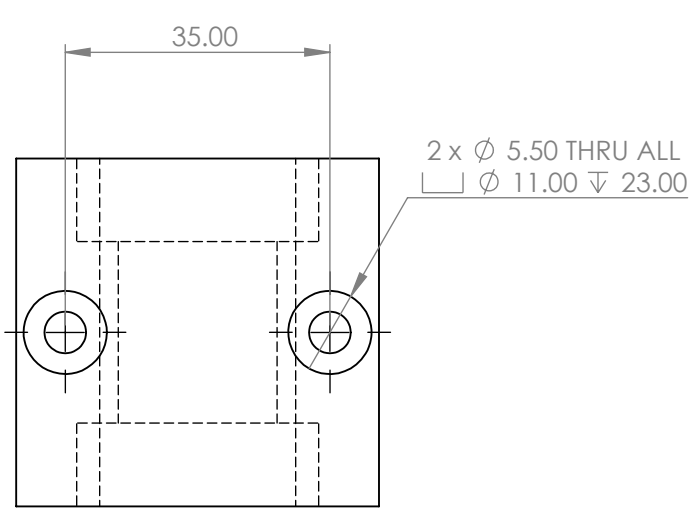
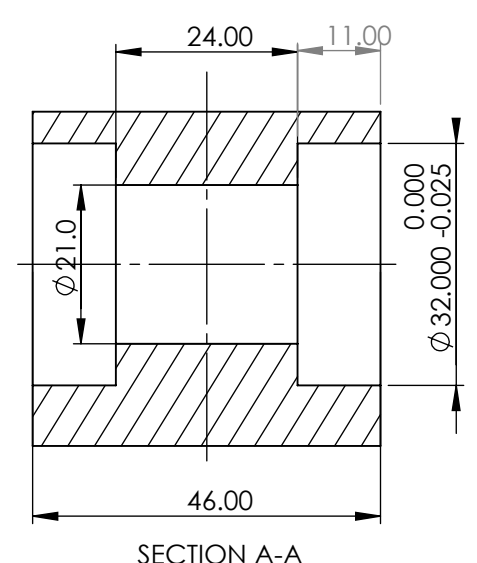
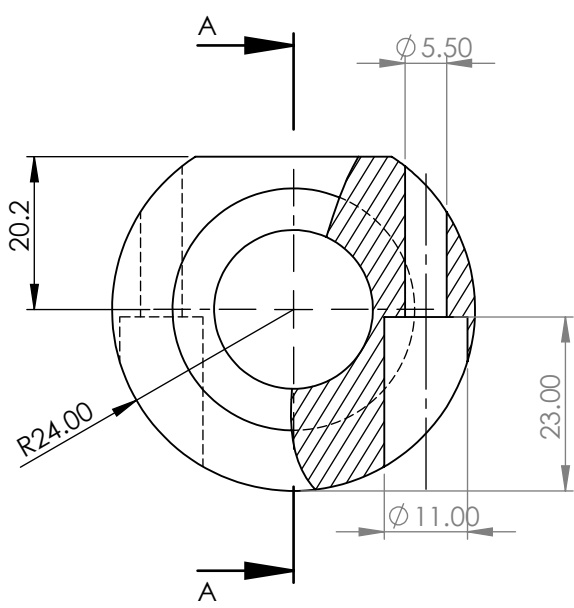

8 Peças p/ Mesa Grande
4 Peças p/Mesa Pequena

UNLESS OTHERWISE SPECIFIED: DIMENSIONS ARE IN MILLIMETERS SURFACE FINISH: TOLERANCES: LINEAR: ANGULAR:			FINISH:	DEBURR AND BREAK SHARP EDGES	DO NOT SCALE DRAWING	REVISION
					Last saved	10/05/2023
NAME	SIGNATURE	DATE	TITLE: Cubo			
DRAWN Pamies Teixeira						
CHK'D						
APPV'D						
MFG						
Q.A			MATERIAL: 2024-T3	DWG NO. CB-01	A4	
			WEIGHT:	SCALE:1:1	SHEET 1 OF 1	

4 3 2 1

F

F

E

E

D

D

C

C

B

B

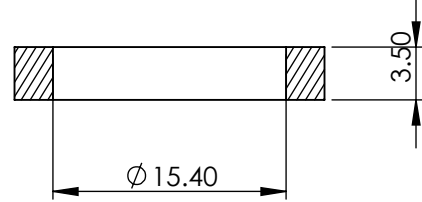
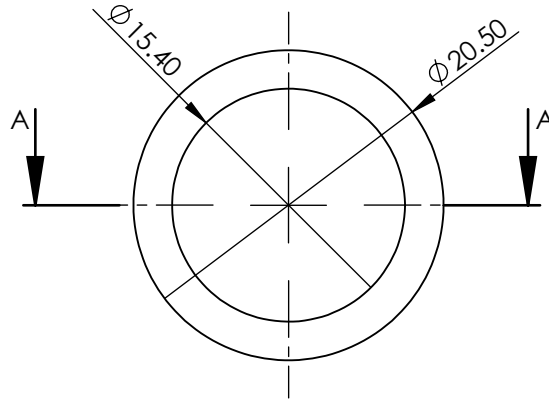

SECTION A-A

UNLESS OTHERWISE SPECIFIED:
 DIMENSIONS ARE IN MILLIMETERS
 SURFACE FINISH:
 TOLERANCES:
 LINEAR:
 ANGULAR:

FINISH:

DEBURR AND
 BREAK SHARP
 EDGES

DO NOT SCALE DRAWING

REVISION

Last saved 09/05/2023

	NAME	SIGNATURE	DATE
DRAWN			
CHK'D			
APPV'D			
MFG			
Q.A			

TITLE:
Espaçador

MATERIAL:
 Material <not specified>

DWG NO.
E-01

SCALE:2:1

SHEET 1 OF 1

4 3 2 1

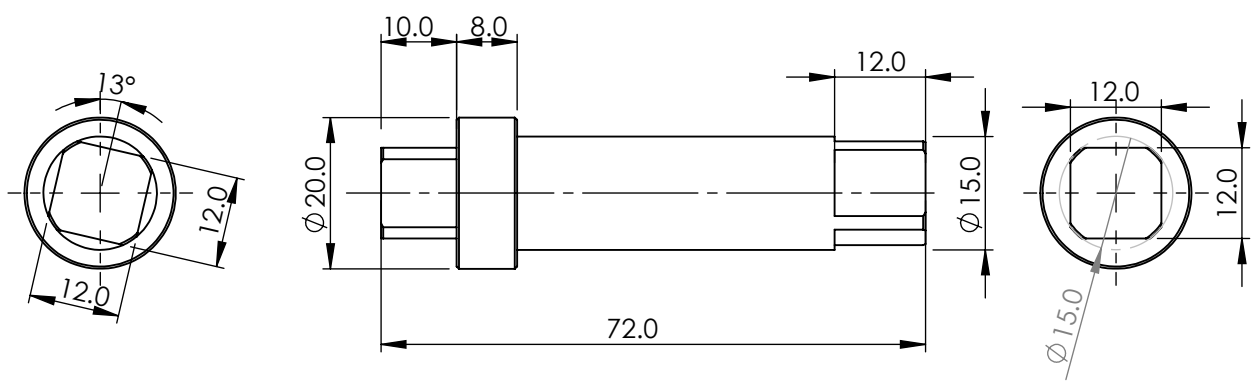

1 Peça

UNLESS OTHERWISE SPECIFIED: DIMENSIONS ARE IN MILLIMETERS SURFACE FINISH: TOLERANCES: LINEAR: ANGULAR:			FINISH:	DEBURR AND BREAK SHARP EDGES	DO NOT SCALE DRAWING	REVISION
					Last saved	11/05/2023
NAME				SIGNATURE	DATE	TITLE:
DRAWN Pamies Teixeira						Veio PX Dto
CHK'D						
APPV'D						
MFG						
Q.A				MATERIAL:	DWG NO.	A4
				2024-T3	V-03	
				WEIGHT:	SCALE:1:1	SHEET 1 OF 1

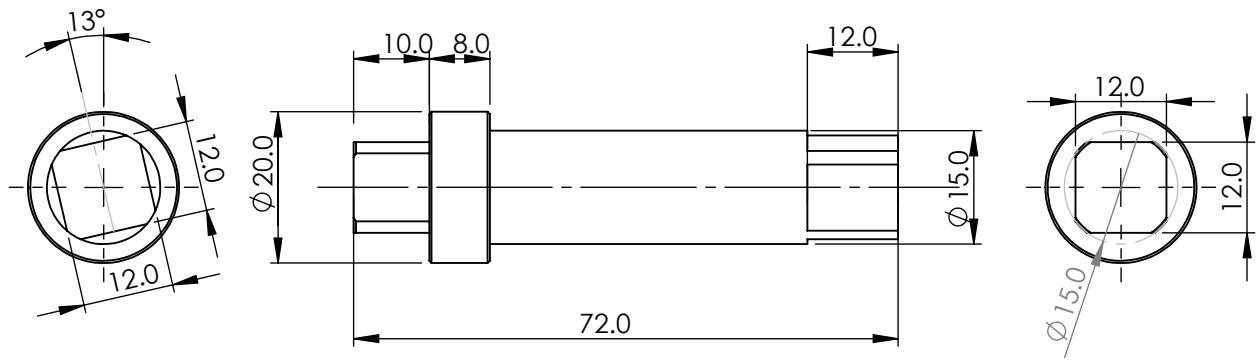

UNLESS OTHERWISE SPECIFIED:
 DIMENSIONS ARE IN MILLIMETERS
 SURFACE FINISH:
 TOLERANCES:
 LINEAR:
 ANGULAR:

FINISH:

DEBURR AND
 BREAK SHARP
 EDGES

DO NOT SCALE DRAWING

REVISION

Last saved 11/05/2023

	NAME	SIGNATURE	DATE
DRAWN	Pamies Teixeira		
CHK'D			
APPV'D			
MFG			
Q.A			

TITLE:	Veio PX Esq	
DWG NO.	V-04	A4
MATERIAL:	2024-T3	
WEIGHT:		
SCALE:1:1		SHEET 1 OF 1